

E-bike with battery (or batteries) fitted.

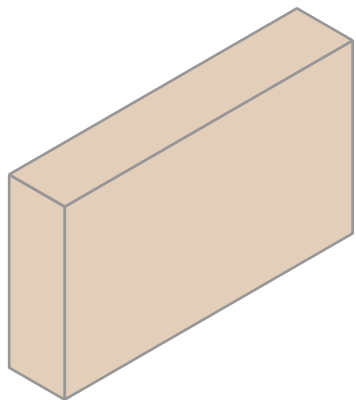

Shipped under UN3171

No ADR restrictions & no additional markings required

E-bike with any separate/additional battery (or batteries) with any one or more not being fitted.

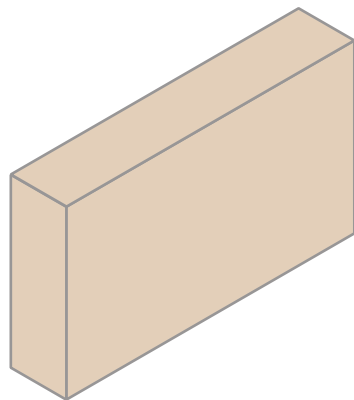

Shipped under UN3481

Must be in UN-approved packaging that is so marked eg 4G/Y22/S/07/GB/2379

Must be marked or labelled with the word "OVERPACK"

Must be marked or labelled with the term "LITHIUM-ION BATTERIES PACKED WITH EQUIPMENT UN3481"

Must be marked or labelled with the following device:



E-bike battery packed separately.



Shipped under UN3480

Must be in UN-approved packaging that is so marked eg 4G/Y22/S/07/GB/2379

Must be marked or labelled with the term "LITHIUM-ION BATTERIES UN3480"

Must be marked or labelled with the following device:



Multiple E-bike batteries packed separately.

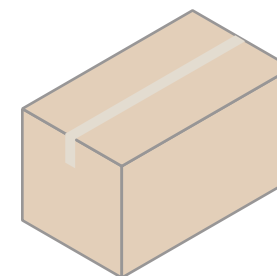

Shipped under UN3480

Must be in UN-approved packaging that is so marked eg 4G/Y22/S/07/GB/2379

Must be marked or labelled with the word "OVERPACK"

Must be marked or labelled with the term "LITHIUM-ION BATTERIES UN3480"

Must bear a statement of the quantity, type and class of goods eg
8 FIBREBOARD BOXES OF UN3480

Must be marked or labelled with the following device:



Shipping these via a courier requires the completion of a dangerous goods note. Most shipping companies have their own but all follow the UK Govt's multi-modal DG note, a copy of which can be accessed here:

https://assets.publishing.service.gov.uk/government/uploads/system/uploads/attachment_data/file/1140895/2023_MULTIMODAL_DANGEROUS_GOODS_FORM_.odt